

ALF M560

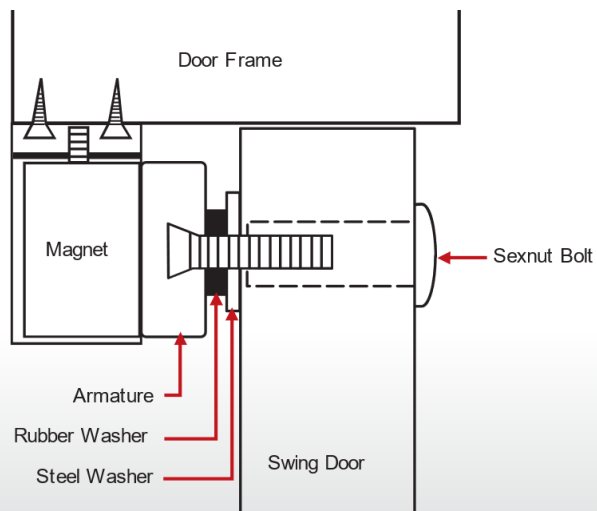

ALF M560 electromagnetic locks are cost effective accessories for a perfect access control system. The model M560 offers 1200 lbs of holding force and is good for all types of doors, while the model M560 provides extra holding power when required. Both models are easy to install and suitable for a large variety of applications. It has no moving parts thus keeping maintenance to a minimum. All types of brackets are available as add-ons to ease installation for both in-swing and out-swing doors.

Installation Guide



Specification

Model	ALF M560
Product Dimension (L*W*H) mm	265*66*40mm
Power Input	12/24 V DC
Current Draw	Stand-by: 250mA, Activity: 500mA
Holding Force	Approximately 900lbs
Type	Fail-Safe

Optional Brackets

L – Bracket

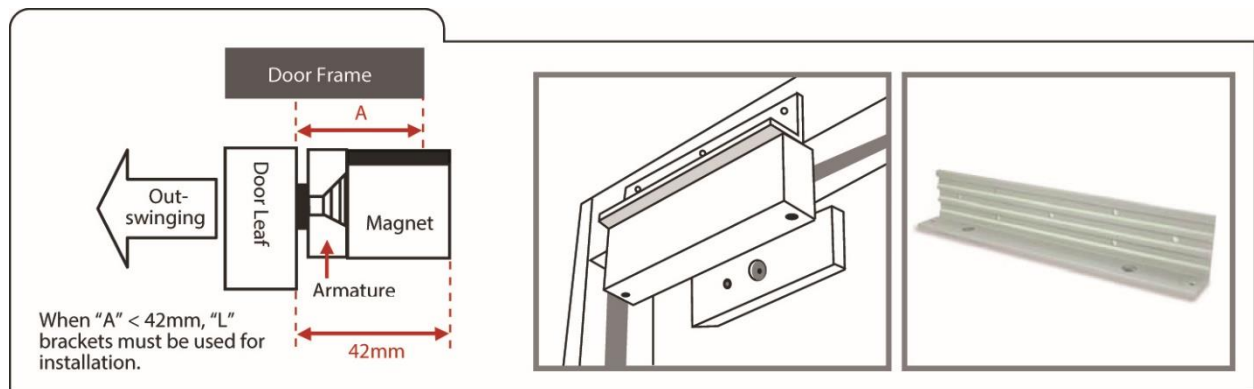

- Adjustable "L" bracket for outward door when the header is narrow.
- Available for M560 Series.

Z - Bracket

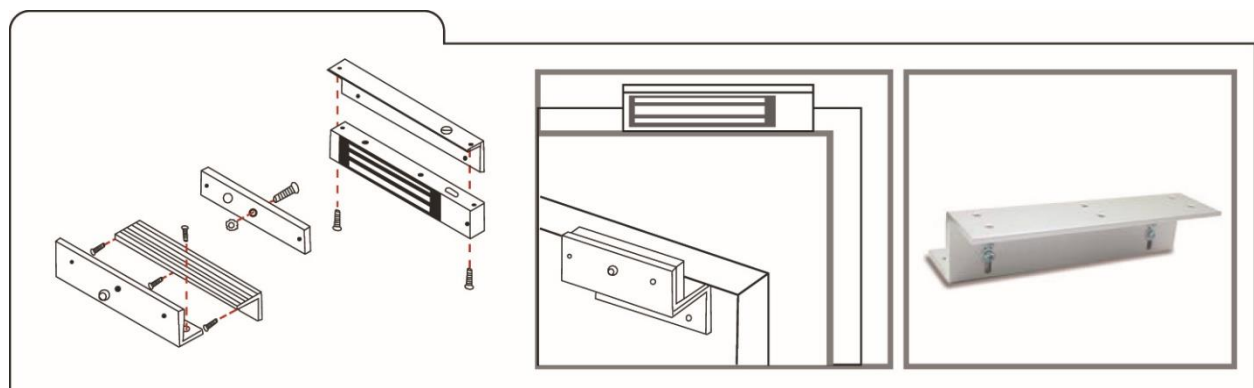

- Adjustable "ZL" bracket for inward door application.
- Available for M560 Series application.

U - Bracket

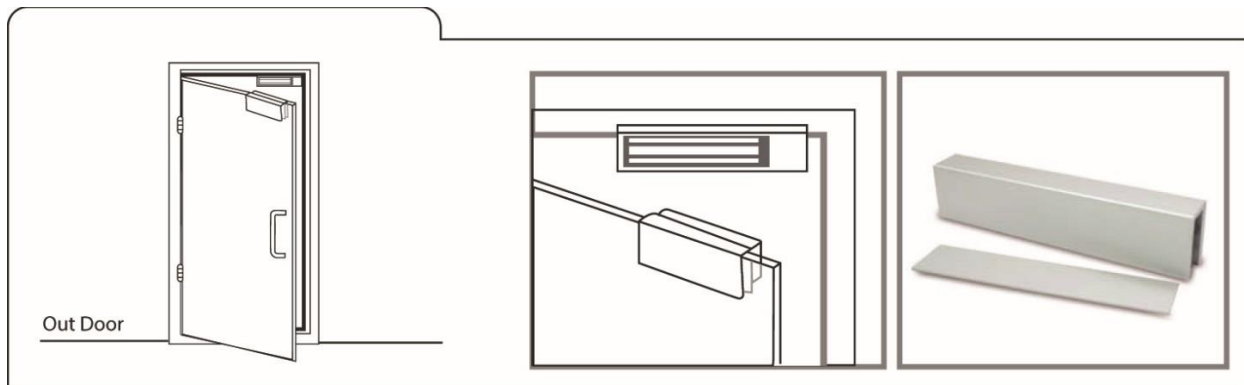

Mounting Diagram

Standard

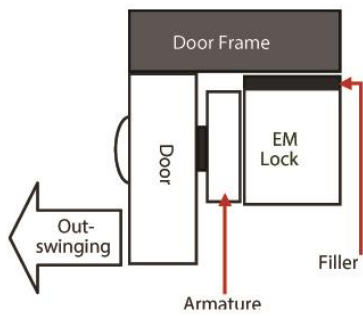

With Filler Plate attached on top of EM Lock.

L - Bracket

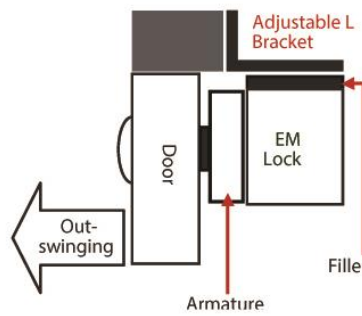

Mounting with "Adjustable L Bracket" when door frame is narrow.

Z - Bracket

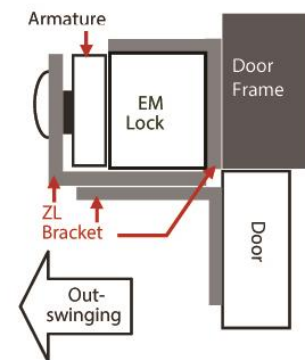

Mounting with " ZL Bracket " for in-swing door application.

Mounting Procedure: Remove the original "Filler Plate" attached to the EM Lock, and replace with " Adjustable L Bracket " set.